

POLIESPANSO CONSTRUCTION SYSTEM

TECHNICAL NOTEBOOK

FLOOR SLAB / ROOF SLAB - PLASTBAU[®] METAL

INSTALLATION STEPS

Introduction - Description - Specifications

- **STEP 1**
Choose model - fields of use and quality advantages
- **STEP 2**
Laying formwork elements (ICF - Insulated Concrete Form)
- **STEP 3**
Laying of reinforcement bars, guide curbs and concrete casting
- **STEP 4**
Installations and finishing

INTRODUCTION

This Technical Notebook contains information for the user as suggestions to facilitate the laying and design of the Plastbau® Metal solution. This document does not describe all laying methods, but only some of them, in that the “best” method in the construction site is subjective, and may be changed according to the physical characteristics and dimension of the elements and the safety rules to be complied with.

DESCRIPTION



Floors and roofs Slab Plastbau® Metal is an Insulated Concrete Form (ICF) consisting of elements 60cm wide. Each element has 2 built-in reinforcement metal profiles - interaxis 30cm - for shoring self-standing up to 2.00 linear meters. The ICF slab formwork system is provided with high density expanded polystyrene (EPS) and elements will stay in place, after casting and aging of concrete, as a permanent floor slab insulation.

Elements have tongue and groove rebate on the edges for a minimum insulation coefficient $U \leq 0,1 \text{ W/m}^2\text{K}$ (*); expanded polystyrene is CE-marked EPS 100, UNI EN 13163 rule, Euroclass E; each element is fitted with 2 longitudinal holes – 12 cm diameter – as an optional passageway for installations.

Plastbau® Metal technology allows to schedule, already during production element's thickness (H+K) to lead to needed structural beam height (H element section) and specific under beam thermal insulation coefficient (K element section).

H element standard section height range:
10 – 28cm (30 – 50cm for big span floor slabs)

K element standard section height range:
3 – 8cm (5 – 8cm for big span floor slabs)

Element length ..cm (*); beam section height ..cm (*);
under beam insulation section height ..cm (*)

(*) Customized

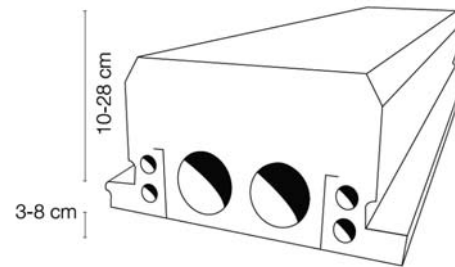

Range degli spessori dell'aletta sottotetto (3 - 8 cm)
Range dell'altezza travetto (10 - 28 cm)

Pannelli di sezione base

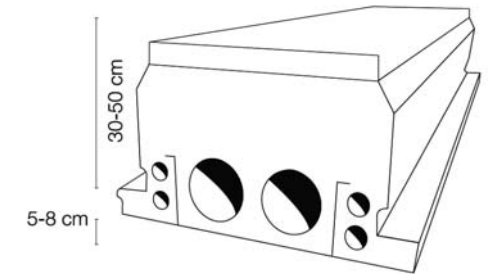

Range degli spessori dell'altezza travetto (5 - 8 cm)
Range dell'altezza travetto (30 - 50 cm)

Pannelli per grandi luci

■ CONDITIONS OF USE

Technical Notebook use: the whole content of this document is copyrighted. Unless otherwise stated, the content is property of Poliespanso Srl – Italy. Partial reproduction of pictures, texts or contents without permission is prohibited

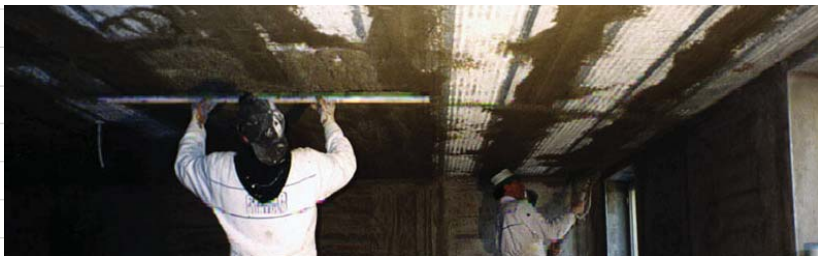

Model I H/K

for internal plaster finishing with galvanized plaster-holder mesh installed

Plastbau® Metal elements Model I shall be coated to the intrados with a stretched, hot-dip galvanized metal grid as plaster support, incorporated in the element to avoid thermal bridges.



Model C H/K

for internal dry finishing with metallic profiles exposed

Plastbau® Metal elements Model C shall be fitted with exposed built-in metal profiles, interaxis 30cm for an easy and fast fixing of any kind of dry finishing.



Model S H/K

for ground floor insulated crawl space

Plastbau® Metal elements Model S are manufactured of EPS only and thus they are not self-supporting; they are laid as crawl space on the ground floor to grant natural ventilation and insulation without thermal bridges.

SPECIFICATIONS

Elements and shall be laid perfectly close to each other on temporary shoring system (props and wooden / H beams only); such a (ICF) floor slab formwork system shall be reinforced with an electro-welded steel mesh, reinforcement steel, as well as the cross-connection of beams, if necessary. Concrete casting in place > Rck 25(C20/25) to form beams and the 5cm-thick floor-slab. Man power, Concrete and reinforcement steel are costs born by the building company locally

PRELIMINARY ESTIMATE AND TECHNICAL ANALYSIS

Poliespanso provides tables and diagrams useful for fast floor slab pre-sizing depending on the floor span and static loads mainly; these tables contain many useful information for a quick and effective estimate.

Poliespanso Technical Unit is at the disposal of engineers to offer assistance during the implementation of the project. Sending DWG files of your project we will provide preliminary technical analysis of the project which includes the choice and offer of the most suitable **Floor Slab Plastbau Metal** solution, pre-dimensioning of the structure, material and manpower estimates and cost analysis.

www.poliespanso.it - on line pre-sizing tools available in Italian language.

STEP 1

Choose model fields of use and quality advantages

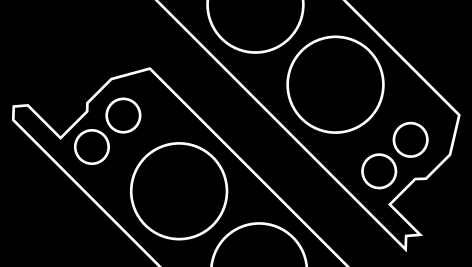

Floor and Roofs Slab Plastbau® Metal allows easy replacement of old-fashioned floors with no extra weight added to structures and foundations, installation is easy as each unit can be moved manually.

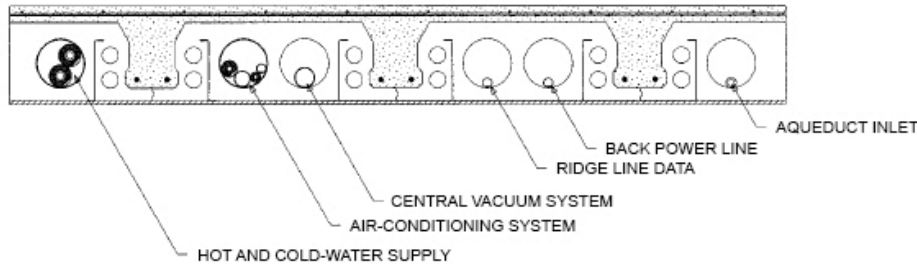

It is possible, furthermore, to optimize slab thicknesses as the installations can be all fitted inside the panel longitudinal holes, thus cutting the floor intrados thickness to the bare minimum. Matching panels by mortice and tenon joint, a beam is created to host core grids (straight, stumps and shaped), to be included in the **Plastbau® Metal** casting, thus eliminating thermal bridges.

possible use in

NEW MULTI-STOREY CONSTRUCTIONS - FLOORS, ROOF and CRAWL SPACE

Slab Plastbau® Metal is used not only for renovations, but also for new buildings and multi-storey constructions. Thanks to its lightness, it is possible to save weight on vertical structures, on foundations and on the logistic costs of construction sites. The **Plastbau® Metal** elements have rebates and insulation is incorporated in the slab structure (ICF) - The insulation level obtained guarantees a significant energy saving. In earthquake-prone areas, **Plastbau® Metal** is particularly suitable, because it is remarkably lighter than traditional floors/slabs. Resistance to fire (REI) of the **Plastbau® Metal** was proved at the CSI lab of Bollate for various types of structural heights and moments of operation.



The formwork can also be mounted manually, without any plants or special means, in areas difficult to be accessed. Since it is supplied tailor-made, according to design, and very light; it does not need other materials, because it is already insulating. Its own weight on site is of around 7 kg/sqm versus around 180kg/sqm of a floor made of brick and concrete. Laying the **Plastbau® Metal** elements is mostly done manually and very rapidly. For instance, a 5 linear meters element is 21kg only.

FLOORS IN RENOVATIONS

Replacing old-fashioned floors and overlapping floors to existing top-quality ones is possible with **Plastbau® Metal** without adding weight to structures and foundations. It also allows to carry out refurbishment of buildings in earthquake-prone areas. Thanks to the manual movement of units, there is no need to use heavy lifting devices.



Venice - slab refurbishment

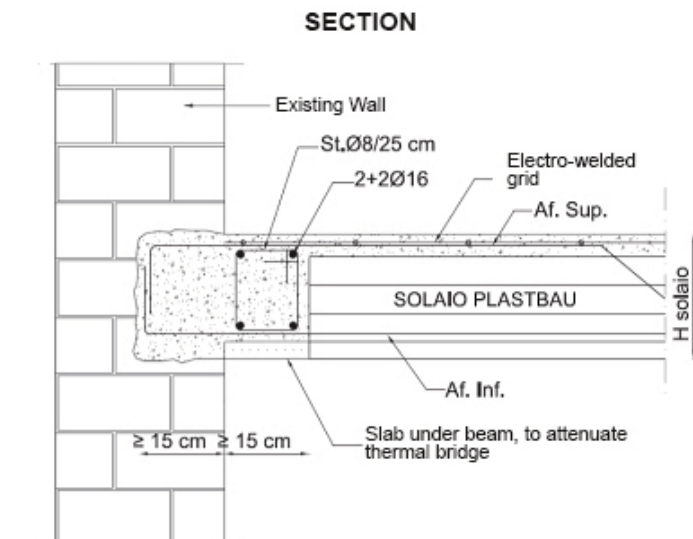

ROOFING

The incorporated heat insulation allows to avoid adding extra insulation layers, if necessary, and to reduce the overall thickness of roofing.



Roofing of a new building



Roofing of a historic building



Insulated crawl space

INSULATED CRAWL SPACE

This **Plastbau® Metal** model is made of EPS only and thus they are not self-supporting; they are laid as crawl space on the ground floor, placed on a sand bed or as overlapped floors to existing structures that need to be replaced. In both cases, the lightness of **Plastbau® Metal** is used both for natural ventilation and insulation without thermal bridges.

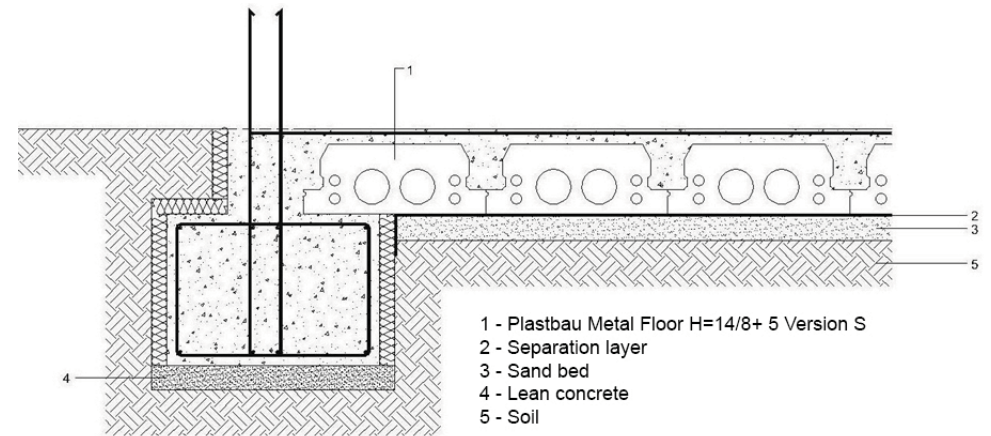

BALCONIES

The use of the **Plastbau® Metal** in balconies allows to solve the thermal bridge simply, rapidly, and at no extra costs.



Laying of the balcony



LARGE-SIZED SPAN FLOORS

Plastbau® production technology allows to manufacture slabs units made to measure, with centimeter accuracy and of any length.



- 1 Floor
- 2 Subsoil
- 3 EPS for thermal bridge correction
- 4 Waterproofing
- 5 Catilever with **Plastbau® Metal** Panels
- 6 Plaster
- 7 **Wall Plastbau® 3**
- 8 Heating + Wall packages
- 9 Light substrate
- 10 Floor with **Plastbau® Metal** Panels
- 11 Plating

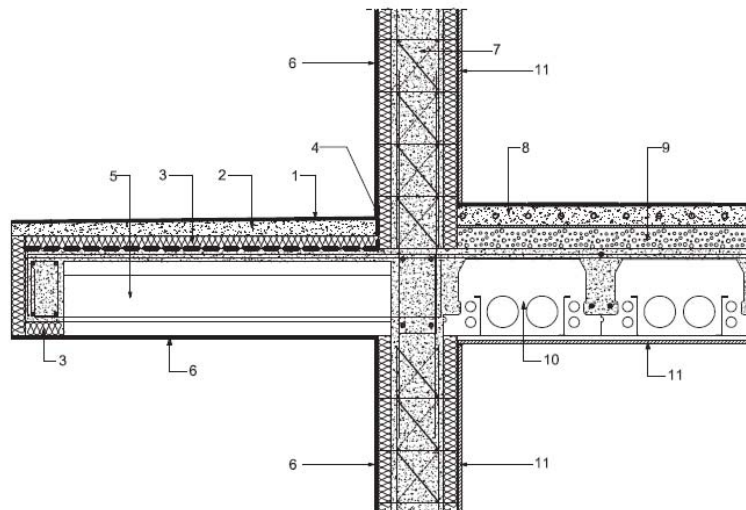

STEP 2

Laying formwork elements
(ICF – Insulated Concrete Form)

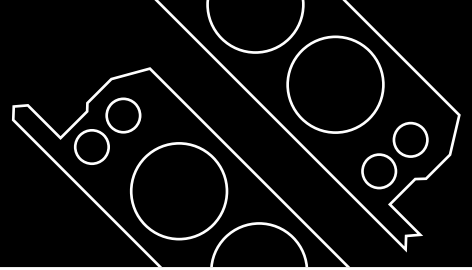

Plastbau® Metal formwork elements (ICF) are always supplied with the mounting scheme and the related detailed product specification list.

The documents drafted indicate the slab areas which are given a letter, while each panel is given a number corresponding to its model.

Plastbau® Metal formwork elements are considered span floors; if Wall **Plastbau® 3** system and the **Slab Plastbau® Metal** are present, slab elements are placed on the internal board of the wall, to maintain insulating continuity.

Elements supplied are 60cm wide, in case submultiples or longitudinally cut panels are needed, the cut shall be easily made directly in the construction site, according to the project.

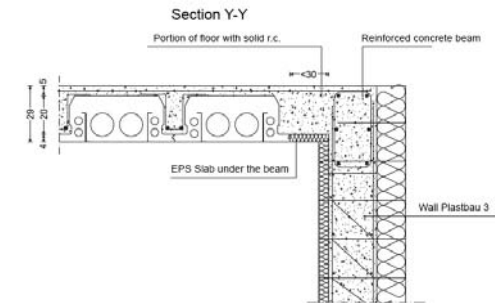
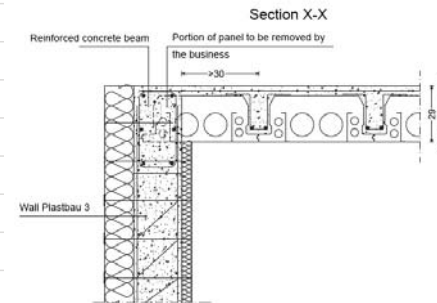
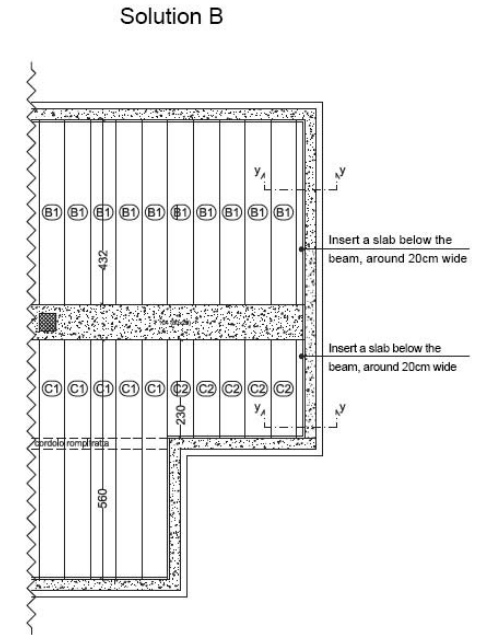
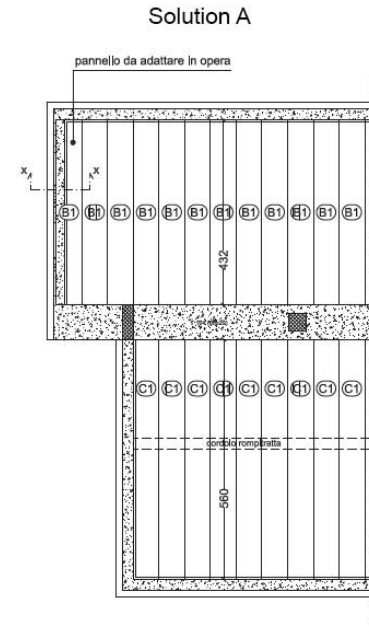

MOUNTING SCHEME

In case of roofs with more than one incline or in case of triangular or trapezoidal areas, trapezoidal panels are supplied, but no corner elements with triangular shape are supplied. In this case, a small area with solid r.c. shall be created in the corners.

DRAWING D

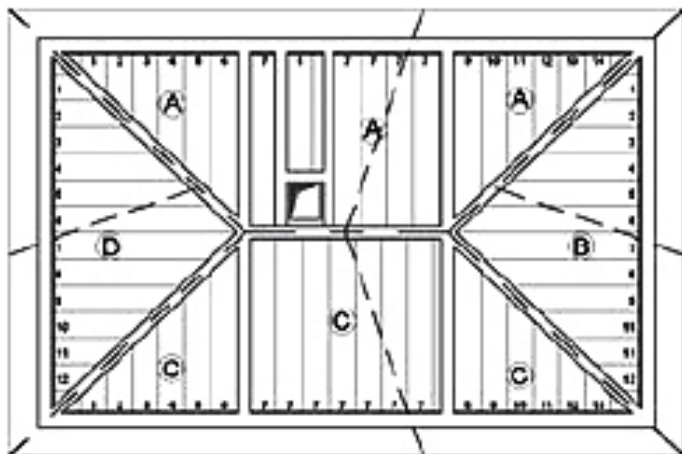

Panels are supplied with a minimum and maximum incline of 6° and 53° respectively (minimum difference between bigger and littler length 6cm; maximum difference between the bigger and littler length 78cm).

DRAWING D'

Maximum cut

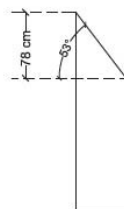

Minimum cut



The product specification list is drafted only after completion of the mounting scheme. The list contains - for each Model of panel (marked by a letter and a number) - the length, the quantity, and the related shape. Such product specification list, after the customer has made the checks, shall be used to produce the material.

EXAMPLE OF A PRODUCTION SPECIFICATION LIST

| POLIESPANSO s.r.l. | | | | COMMESSA NR. | |
|---|-------------------------|--|--|-----------------|-----------------|
| Via: A. Vespucci 10, Mantova Uff. Tecnico - Tel. (0376) 343032 Fax. (0376) 343020 E-mail: malucci@poliespanso.it | | | | COMMITTENTE: | |
| | | | | CANTIERE: | |
| ORDINE INTERNO NR. | | | ORDINE ACCETTATO NR. | | |
| DATA: | | OGGETTO: Solaio Piano Terra Plastbau Metal | | | |
| CODICE ARTICOLO | C 18/4 | CODICE ARTICOLO | C 20/8 | CODICE ARTICOLO | CODICE ARTICOLO |
| QUANTITA' MQ. | 75.438 | QUANTITA' MQ. | 110.586 | QUANTITA' MQ. | QUANTITA' MQ. |
| TOT. MQ COMMESSA | | ACCESSORI: LASTRE SOTTOTRAVE | | | |
| 186.024 | | Spess. 4 cm Dimens. 4x100x200 N°22 | | | |
| | | Spess. 8 cm Dimens. 8x100x200 N°23 | | | |
| Nome campata | Lunghezza pannelli (ml) | Numero pannelli | Forma dei pannelli Larghezza cm. 80 (fissa) | Tipo | Note |
| A1 | 2.29 | 1 | | C 18/4 | |
| B1 | 4.55 | 4 | | C 20/8 | |
| B2 | 2.73 | 1 | | C 20/8 | |
| B3 | 4.39 | 1 | | C 20/8 | |

The drafted document also contains the precautions to lay the slab elements correctly, with the indication of the slab area, the maximum center distance of temporary struts for shoring system, the section of the reinforced cross-piece (bond-beam) and any other operational detail.

SHORING SYSTEM - PROPS & WOODEN BEAMS / H BEAMS

Each supply of **Plastbau® Metal** formwork elements comes with specific execution drawings for mounting and positioning of concrete reinforcement steel. Follow this procedure:

Place shoring system with props and wooden beams to the distance as indicated in the technical documents- see model in normal direction as compared to that of the elements / **Plastbau® Metal** panels. Props must be suitably stiff and braced in order to ensure the strength required by the structure designer / engineer.

The props must be approved, with an adequate diameter, load and section, and if possible, with adjustable height and equipped with specific technical sheets that define their payload according to their effective length. Shoring system must be placed on a solid, well-compacted soil, on load sharing elements, be fixed solidly to the base and the timbering on top, using nails or an equivalent system.



Self-standing
A fundamental characteristic of the Plastbau Metal Floor is self-standing, by the 2 galvanised metal profiles incorporated in the panel. They allow to bear loads during the casting phase. It is only necessary to place temporary struts at a centre distance of 2m.

HANDLING

When being handled and laid, the **Plastbau® Metal** formwork elements must be grasped by placing the hands into the large holes (as indicated in the picture). Panels should never be handled by taking them from the edge (external wings): since they are not thick enough, they may break, thus jeopardising the insulation continuity to the floor intrados and the correct laying. We recommend using gloves to avoid cuts caused by metal elements inserted in the panel.

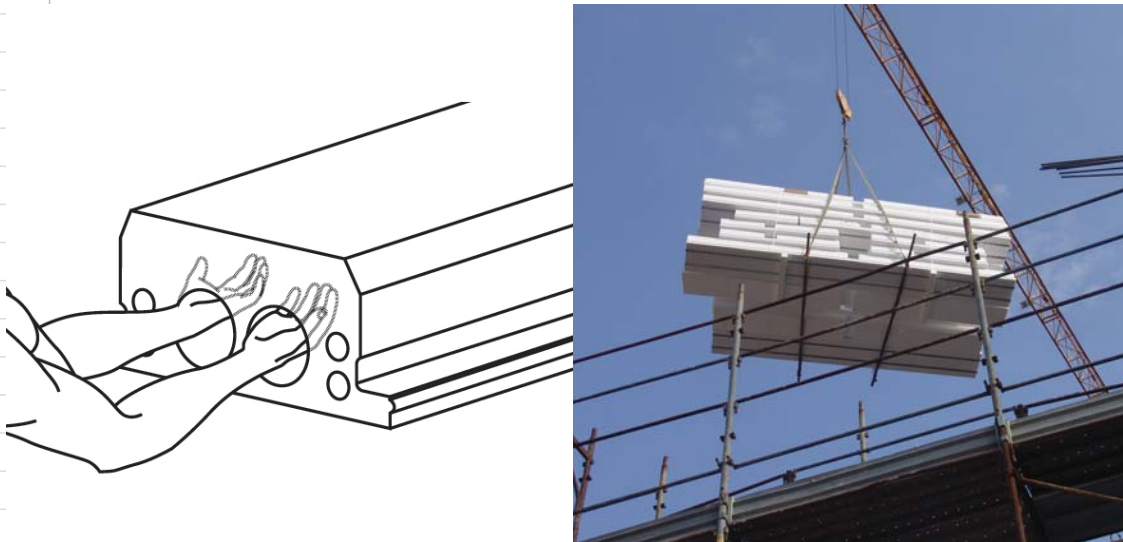

POLIARMO - UNDER BEAM INSULATION BOARDS

In case beams and bond-beams are envisaged in the floor thickness, we can provide Poliarmo as a under beam insulation board in order to eliminate thermal bridge; it is necessary to evaluate which beams and bond-beams are to be insulated.

POLIARMO is a panel of expanded polystyrene (EPS) of the type Poliespanso 120, suitably shaped to guarantee that beam and plaster hold on to concrete, without using mechanical anchoring. Combined with the **Plastbau® Metal** formwork-floor, it eliminates the thermal bridges of the floor at the beam level. Upon request, according to the heat insulation requirements or construction specifications, it is possible to choose the most suitable thickness and EPS density.

POLIARMO board is pre-engraved to be adjusted manually in width to submultiples. Pre-engraving allows to adjust the board to different sizes. All you have to do is identify which pre-engraving to use as a separation line - Slightly flex the two edges, or insert a cutter blade, and you're done.

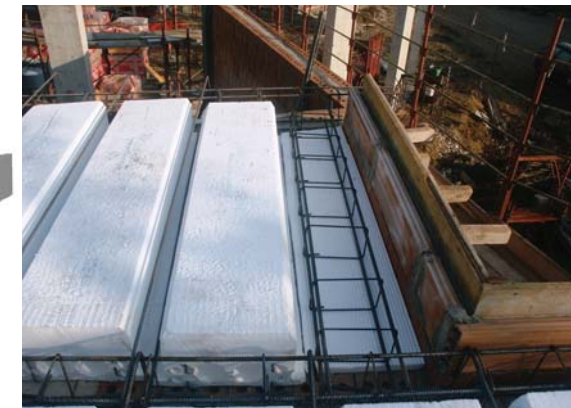
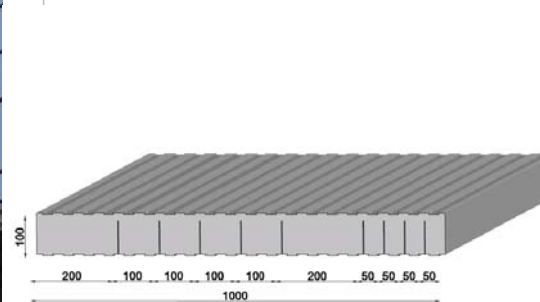

POLIARMO allows to have straight slabs with perfectly parallel edges and to eliminate waste almost entirely, because of the possibility to place one slab close to the other, until the desired width is reached. Combined with the **Plastbau® Metal** formwork, it eliminates under beams thermal bridges of the entire floor slab.

STEP 3

Laying of reinforcement bars
guide curbs and concrete casting

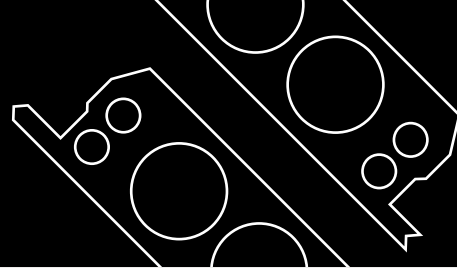

Floor / Roof Slab Plastbau® Metal is a variable geometry formwork panel with integrated heat insulation for the construction of floor slabs to be reinforced and casted in place. Reinforcements steel rods shall result from the static calculation made by the engineer in charge of structures, according to the rule in force. The engineer shall determine the structural thickness of the slab considering that beams have interaxis center distance $(i)=60\text{cm}$; beam's width has 2 dimensions $B=13\text{cm}$ and $b=11\text{cm}$.

IN-SITU LAYING OF REINFORCING BARS

Once the panels have been positioned to form the floor, along with beam and peripheral bond-beams reinforcements, it is possible to start placing the reinforcement bars as envisaged.

The floor/roof slab reinforcing steel rods be laid following the structural document, where the reinforcing steel refers to every single beam.

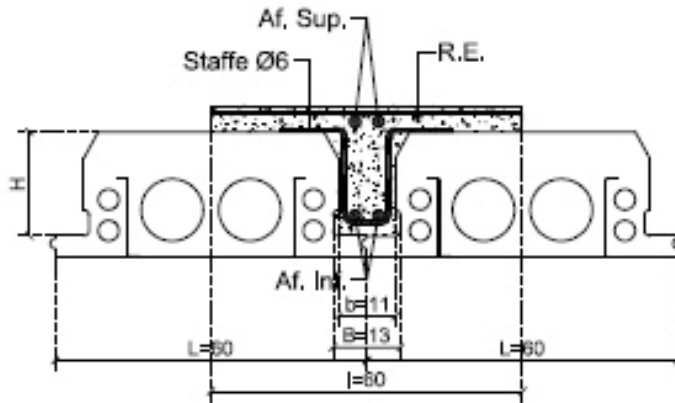

Steel Brackets Ø6mm are placed into the spaces of floor beams before casting, at a distance of 150cm between one another; brackets will support the lower reinforcing bars detaching them from the panel bottom and ensuring the minimum concrete cover to reinforcement.

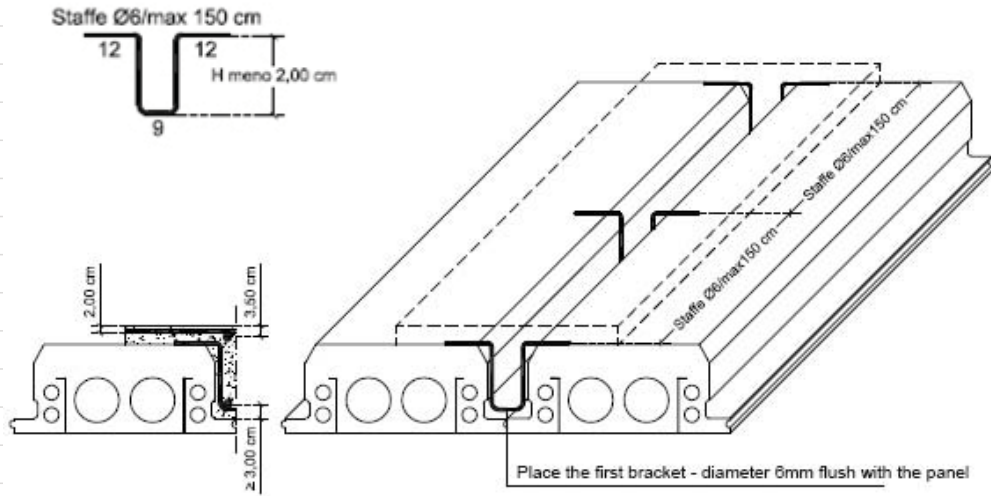

The upper reinforcing rod of beams shall be placed at the level of stands and tied below the electro-welded steel grid.

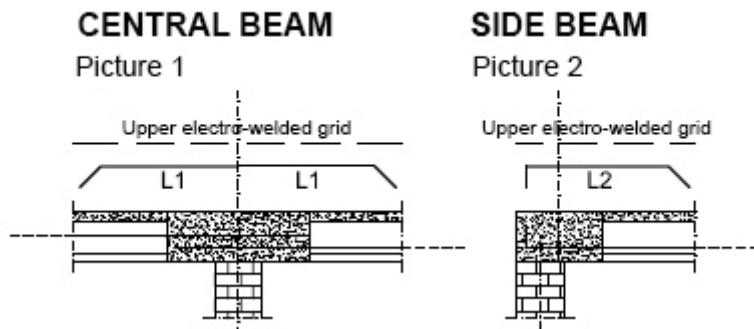

GUIDE CURBS

If the reinforced concrete calculator envisages panels whose length is 5m or more, the cross-piece (bond-beam) is inserted; usually in the centerline and 25cm wide, unless otherwise stated.

Such ready space in the **Plastbau® Metal** elements will be obtained directly in the factory.

The normal guide curbs, transversal to the floor framing direction, are built with the same thickness of panels, removing a part of EPS from the 16cm thickness from the panel intrados without touching self-standing metal profiles.

The types of guide curbs available for the **Plastbau® Metal** Floor are differ according to the height of the element/panel.

- A) guide curbs with 4 bars in line, with brackets in the beam; Drawing 1**
- B) traditional guide curbs with 4 bars, with cage brackets. Drawing 2**

Where a guide curb is envisaged, shoring full support should also be suitably envisaged.

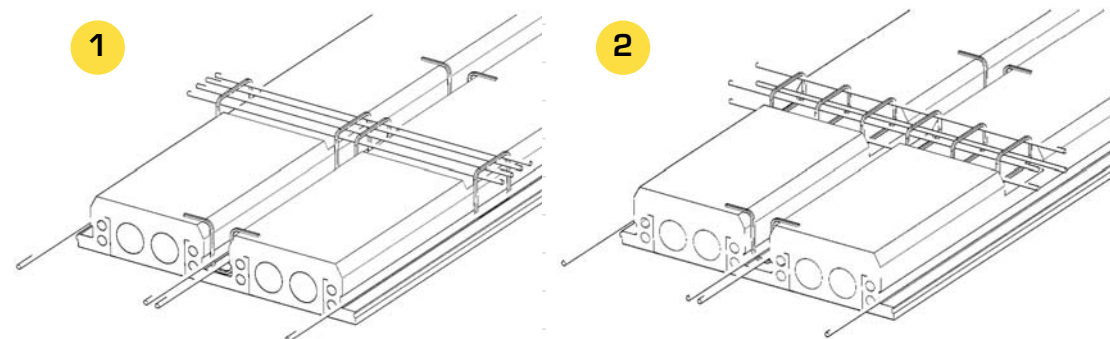

for beam heights up to 19cm

for beam heights of 20cm or more

SHEAR AND PUNCHING REINFORCEMENT

Brackets may be used to absorb the exceeding shear and punching load at the support level, packing them at a lower distance as indicated in the drawing.

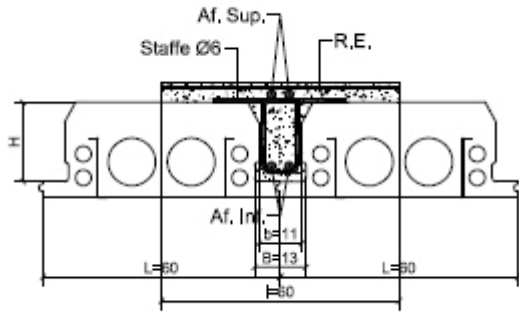

In the areas where brackets are more packed, place brackets of 6mm diameter as indicated in the drawing.

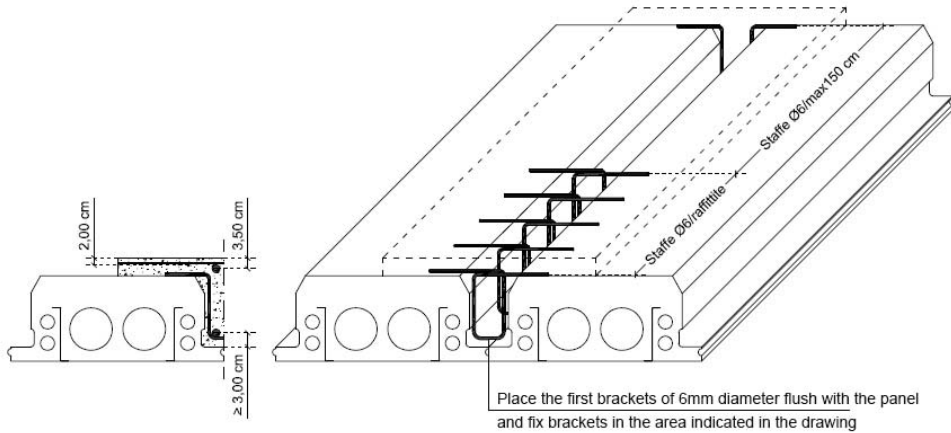
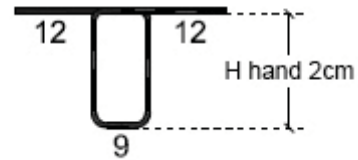

Place the first brackets of 6mm diameter flush with the panel and fix brackets in the area indicated in the drawing



REINFORCEMENT MESH

The upper electro-welded steel mesh - sharing loads - should always be placed above the reinforcement rods grid of beams and bond-beams, with and overlapping in span of at least 2 meshes.

The type of reinforcement mesh to be used shall be indicated in the static calculation made by the engineer in charge of structures.

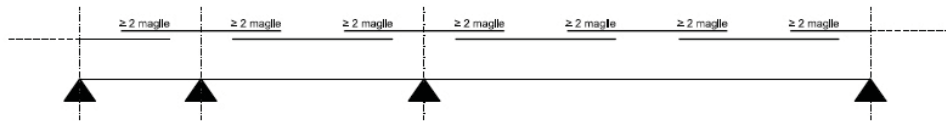

CONCRETE CASTING

Before casting, make all the necessary checks, assessing the correct positioning of cross-pieces (struts), beams, checking that all formwork panels are closed by caps and perfectly close to the slabs under the beams. It is also necessary to seal with EPS or other suitable polyurethane foams any holes due to breaks, to avoid CLS drains and the subsequent thermal bridge.

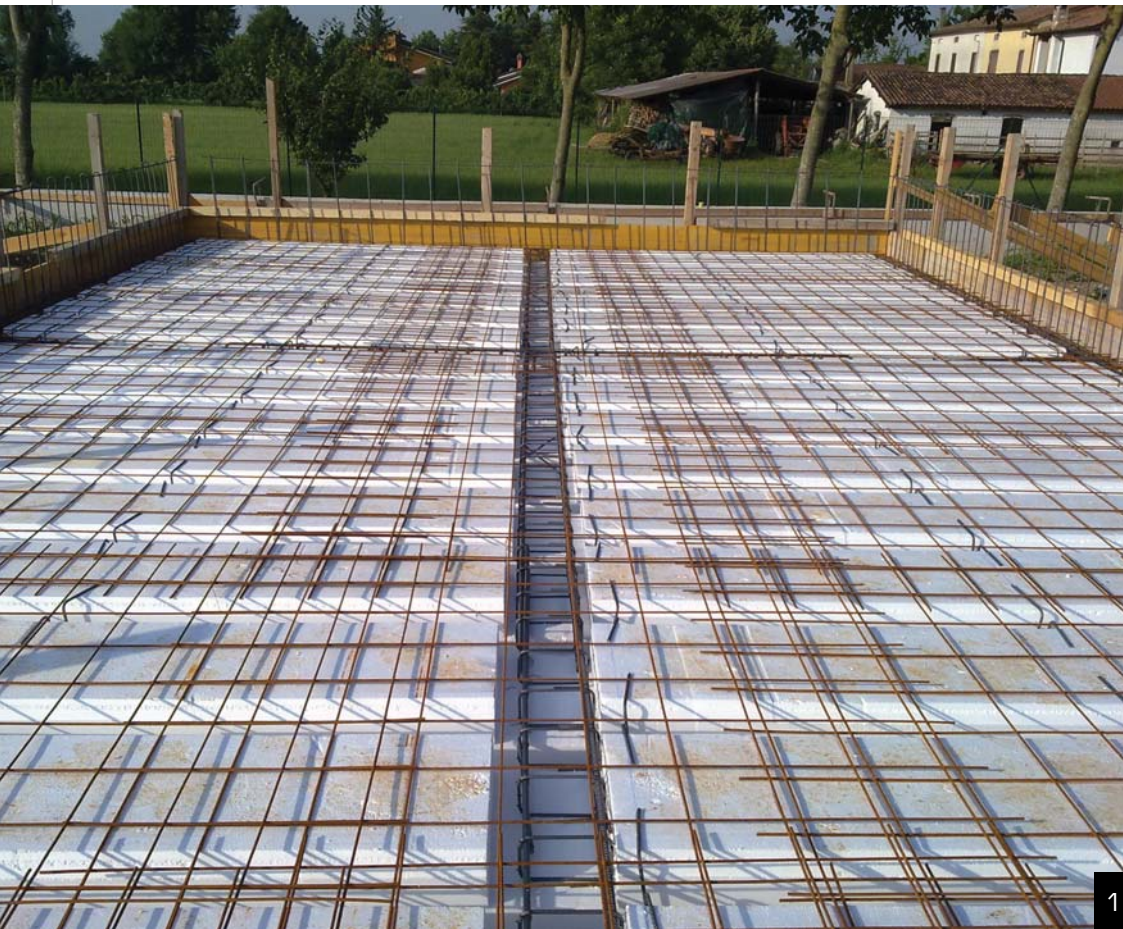

STEP 4

Installation and finishing

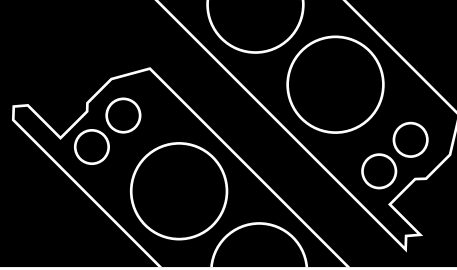

INSTALLATIONS

Another functional feature of floors and roofs **Slab Plastbau® Metal** is the use of longitudinal holes, Ø 120mm to insert installations. Insertion may be carried out before casting, working at the extrados level, but also after casting, working at intrados level.



Plastbau® Metal exposed steel profiles at the intrados level, besides supporting ceiling grid – may also hold installations, pipe-holders or bundles of pipes.

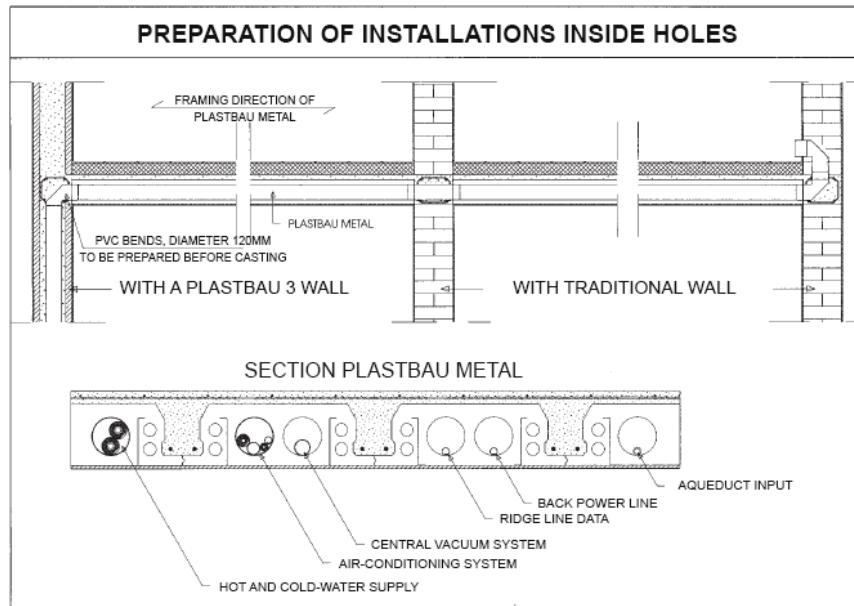

HANGING LIGHT FITTINGS

Fitting for the hanging of lightweight light fixtures once the floor has been completed, with electrical wires inside the holes of the **Plastbau® Metal Floor**: see scheme below

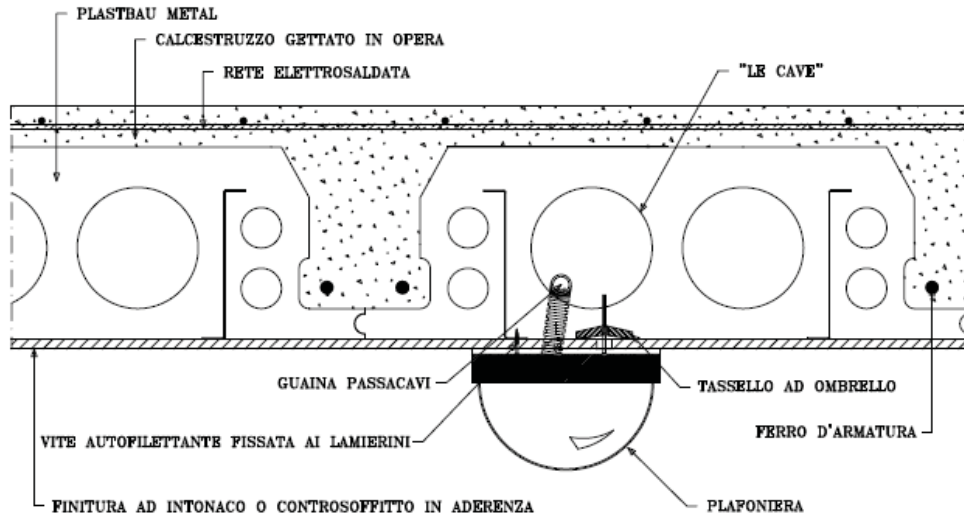

Fitting for the hanging of lightweight light fixtures once the floor has been completed, with a non-adhering false ceiling. Umbrella-shaped anchor sleeve fixed to the plasterboard slab, with electrical wires inside the holes of the the **Plastbau® Metal Floor**: see scheme below

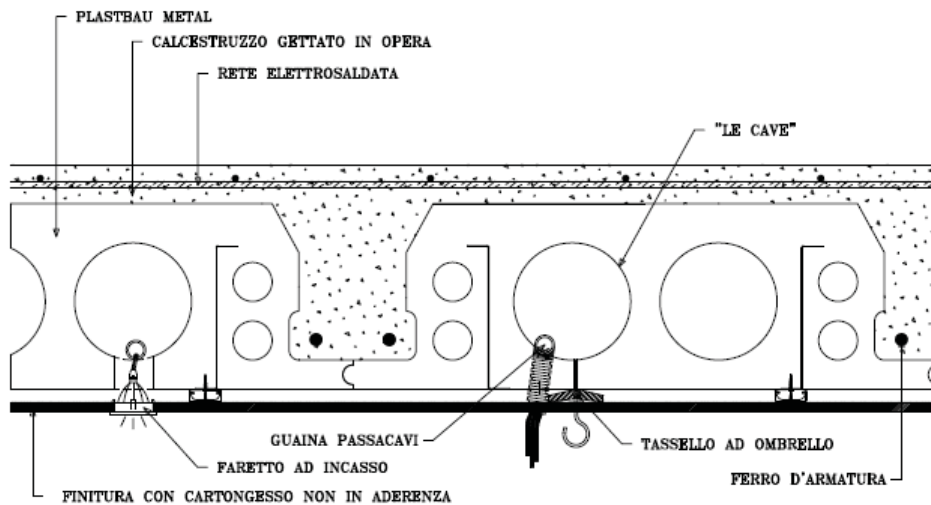

INTERNAL FINISHING

EPS does not behave like bricks, and this needs to be considered when the slab intrados must be plastered, **because it does not absorb water and the dilation coefficient is different.**

Plastbau® Metal - Model I .../... with galvanized plaster holder mesh installed

Plaster holds on easily and job is fast because the intrados surface of Plastbau® Metal elements have a galvanized plaster-holder mesh already installed. The best result is obtained using ready-to use, pre-mixed cement based on plaster, lime, and expanded perlite, laid directly, manually or using a machine, according to the prescriptions by the plaster manufacturer.



Laying of the machine

Splice plate grid

Protocols for internal plastering - manufacturers and related product types

| | | | |
|---------------------|--------|---------------------|--------------------|
| RÖFIX | 190 | Gyproc Saint gobain | Monocote lite |
| RÖFIX | 195 | KNAUF | MP-2 |
| Gyproc Saint gobain | Surmix | KNAUF | Roccia di Gambassi |
| Gyproc Saint gobain | ipm 70 | GRIGOLIN | GS08 |

Recommendations

A high thermal differential between the external and internal surfaces, for instance in a roofing, may give rise to microcracking of plaster at panel junction level. In this case we recommend laying a joint cover plaster mesh.

Plastbau® Metal - Model C .../... for internal dry finishing with metallic profiles exposed

It is possible to apply various types of finishing according to architectural requirements. The smooth EPS surface is ideal for coarse skim plaster, both internal and external. Thanks to the metallic profiles included in the panel, adhering, or lowered false ceilings can both be laid.



Skim plastering:

It is possible to finish the intrados of **Plastbau® Metal** elements without the hot-dip galvanized mesh for plaster, with skim plaster, using a suitable layer of adhesive/skim plaster in which the glass-fiber mesh will be immersed, in the last third of thickness of the skim plaster.

Protocols for external plastering - manufacturers and related product types

| | | | |
|-------|--------|-------|----------------|
| KNAUF | SM 700 | RÖFIX | UNI STAR LIGHT |
| KNAUF | SM 760 | | |

Recommendations

In floor slabs that have long been exposed to rain or snowfall, we recommend - before finishing the intrados - to make a visual check, to identify possible water dripping from the floor. Dripping indicates that inside the slab holes water is stagnating, and it must be eliminated prior to finishing. Once the dripping point has been identified, just make a couple of holes in the floor intrados at the level of panel technical holes.

False ceilings and dry cladding

Lowered or adhering false ceilings, applied in the various ways available on the market, may be obtained using normal self-tapping screw directly on galvanized metal profiles incorporated in the product. Such edges have a 30cm center distance – interaxis - and appear as strips flush with the intrados, 35mm wide and 0.8mm thick. According to tests carried out, the Ø3.9mm screws have a pull-out resistance of 35kg.



Secondary frame for plate screwing



Wooden false ceiling



Lowered and dropped false ceiling

Specification

*All products listed above are to be applied in strict compliance with the technical specifications of each manufacturer, and, particularly, thicknesses, the time and methods of application. All finishing applications concerning the intrados of the **Plastbau® Metal** elements are the direct responsibility of professionals engaged in the application. By reading the technical sheets and asking for advice to the manufacturers, they must assess the compatibility of materials to apply and the most suitable methods for laying, which also depend on climatic conditions.*



**Museo del '900
Arengario Milan**

Renovation



**Business premises
Corso Como, Milan**

New construction



**Residential building
Dakar, Senegal**

New construction



**University Cà Foscari
Venice**

Renovation



**Residential building
Towers in Piazza
Drago Jesolo**

New construction



**Nuovi Uffizi Gallery
Florence**

Renovation

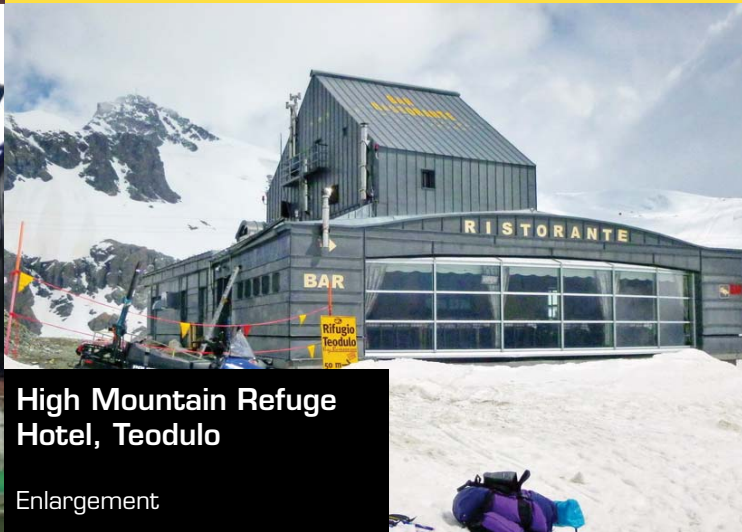

**High Mountain Refuge
Hotel, Teodulo**

Enlargement



**Office building,
Adria Rovigo**

New construction

Poliespanso S.r.l.

Zona Ind. Valdaro - Via Amerigo Vespucci 10, 46100 Mantova

Tel. +39.0376.343011 - Fax +39.0376.343020